



**FASTER EASIER STRONGER**

153 BOWLES ROAD

AGAWAM, MA 01001-3824

413-789-0252

FAX: 413-786-1760

[www.fastenmaster.com](http://www.fastenmaster.com)

November 16, 2009

Good morning,

I appreciate your time and interest at your code meeting in Westport, Connecticut, October 27. There were some great questions at that meeting. There was also very strong interest in the new application of the Rafter Tail/Truss Heel to the Top Plate as an alternate method of fastening rafters and trusses in your area of Connecticut.

One question in particular, I wanted to research before I answered. That was the question regarding the withdrawal into end grain. Here is the NDS: 11.2.1.2 When lag screws are loaded in withdrawal from the end grain, reference withdrawal values,  $W$  shall be multiplied by the end grain factor,  $C_{eg} = 0.75$ . So, if a TimberLok or HeadLok has 131 lbs of withdrawal per inch of penetration into Spruce Pine Fir, the end grain factor would reduce it to 98 lbs per inch or 196 lbs versus 262 lbs into the side grain.

Please find enclosed a Rafter-Tail to Top Plate Starter Kit which will enable you to share this application with the builders in your area. The Rafter Tail Technical Bulletin will give you and your builders all the information they need to start using this application properly. The enclosed HeadLoks and TimberLoks will allow them to get started on their next project.

We have been doing some exciting testing with the Structural Building Component Research Institute in Madison, WI. The reports should be available soon. There is an exciting video that I can email you showing an example of the excessive uplift loads the LOKs withstand. Please email me your address and I will send it out to you right away.

Please do not hesitate to call me with any questions or concerns you may have

Yours truly,

Brice Hereford  
LOK Product Manager

Ps- You may want to go to our website (<http://www.FastenMaster.com/>) to see the latest information and offerings for your builders.



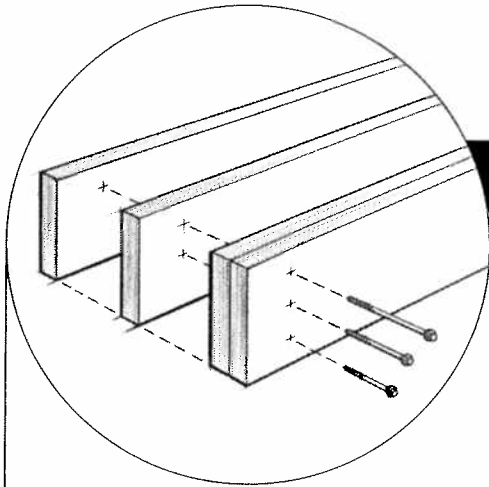

## MULTIPLE MEMBER ENGINEERED WOOD BEAMS

### CONNECTION DETAILS

The TrussLok Engineered Wood Fastener has been designed specifically for use in joining multiple-ply engineered wood beams (LVL, LSL & PSL). Using a standard corded or cordless 1/2" low speed/high torque drill, install screws into the side of the outermost ply. As the thread fully engages the final ply, allow the underside of the washer head to pull the plies firmly together. Do not attempt to countersink the fasteners as this may damage the beam. Refer to the information in this bulletin for proper fastener size selection and fastening pattern.

### FASTENER SIZE SELECTION

1 3/4 1 3/4

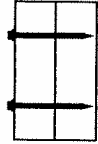

3 3/8"  
TRUSSLOK

3 1/2 3 1/2

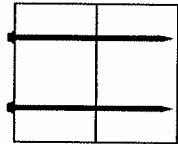

6 3/4"  
TRUSSLOK

1 3/4 1 3/4 1 3/4

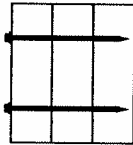

5"  
TRUSSLOK

1 3/4 1 3/4 1 3/4 1 3/4

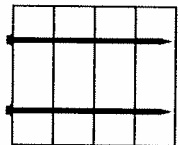

6 3/4"  
TRUSSLOK

1 3/4 3 1/2

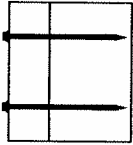

5"  
TRUSSLOK

1 3/4 3 1/2 1 3/4

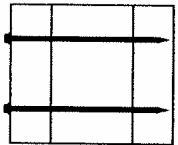

6 3/4"  
TRUSSLOK

### FASTENER IDENTIFICATION

For easier selection and post-installation inspection, all TrussLok fasteners carry an identifying head marking.

TrussLok 3 3/8" . . . . F3.3

TrussLok 5" . . . . . F5.0

TrussLok 6 3/4" . . . . F6.7

### MINIMUM SPACING REQUIREMENTS

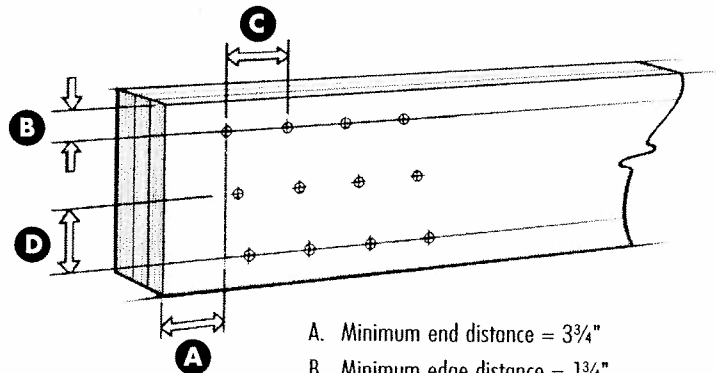

A. Minimum end distance = 3 3/4"

B. Minimum edge distance = 1 3/4"

C. Minimum spacing between fasteners in a row = 3 1/2"

D. Minimum spacing between rows of fasteners = 5/8"

### GENERAL GUIDELINES

- Beams wider than 7" require special consideration by the design professional. The values on the next page do not apply.
- Excessively warped or curved LVL should never be forced into alignment by use of clamps, screws or bolts as splitting may occur, potentially decreasing the carrying capacity of the beam.
- To avoid damaging the beam, fastener heads must not be countersunk. However, if the TrussLok head needs to be brought flush, prepare the outermost ply with a countersink before installing. Using a 1/2" spade bit, drill a 1/4" deep well into the LVL in the desired fastening pattern, then install the TrussLok flush.
- Not designed for use with dimensional lumber. Use FastenMaster's TrussLok-Z fastener for multiple member dimensional wood beams.
- A qualified designer or engineer should always be consulted for critical assemblies and fastening requirements.



Effective until January 1, 2010. Updated information must be obtained after this date.

153 BOWLES ROAD, AGAWAM, MA 01001

413-789-0252

800-518-3569

WWW.FASTENMASTER.COM

**FASTENING PATTERN**

**Top Loaded Beams**

Where all floor joists sit on the beam, fasteners should be spaced two every 24" on center in a staggered pattern as shown.

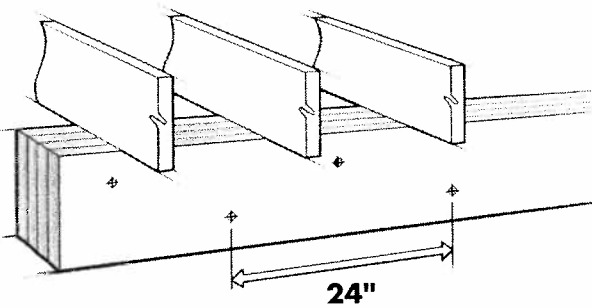

For beam depths of 18" or more, this pattern should be increased to three fasteners every 24" on center.

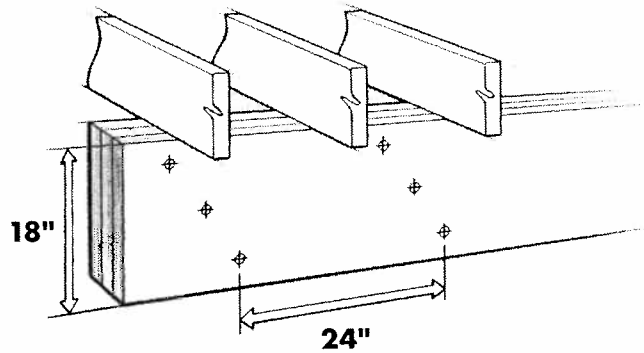

**Side Loaded Beams**

Where floor joists are joined to the side of the beam (typically using a joist hanger), this load chart must be used to establish the proper pattern based on the design load as determined by the engineer and noted on the plans.

- Allowable loads are derived from tested fastener values as reported in ESR #1078 (see [www.icc-es.org](http://www.icc-es.org)).
- A specific gravity of 0.5 was used for all engineered wood (EW) calculations.
- The uniform loads in this table relate only to the capacity of the fastener to transfer shear loads between plies. The capacity of the EW beam may be less and should be checked against the manufacturer's literature.
- Values listed reflect 100% stress level ( $C_D=1.0$ ). The designer may apply adjustment factors to increase or decrease these loads per 2005 NDS based on conditions for each assembly.
- To minimize rotation, 7" wide beams shall be side loaded only when loads are applied to both sides of the beam with the lesser loaded side bearing at least 25% of the overall design load.

**Assembly Type**

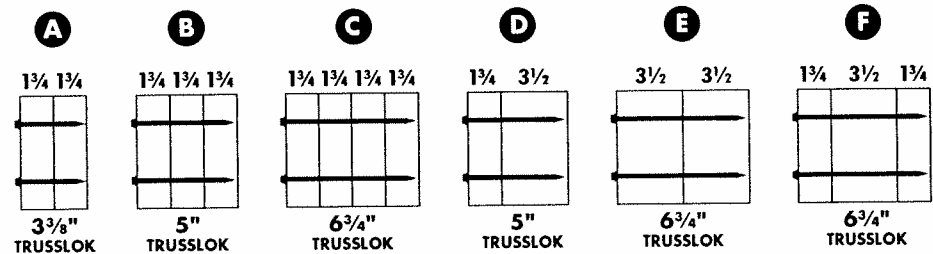

TRUSSLOK	SCREWS	SPACING	ASSEMBLY TYPE					
			A	B	C	D	E	F
3 3/8"	2	24"	534					
	2	16	801					
	2	12	1068					
	3	24	801					
	3	16	1202					
	3	12	1602					
5"	2	24"		433		433		
	2	16		649		649		
	2	12		866		866		
	3	24		649		649		
	3	16		974		974		
	3	12		1299		1299		
6 3/4"	2	24"			387		580	387
	2	16			580		870	580
	2	12			773		1160	773
	3	24			580		870	580
	3	16			870		1305	870
	3	12			1160		1740	1160

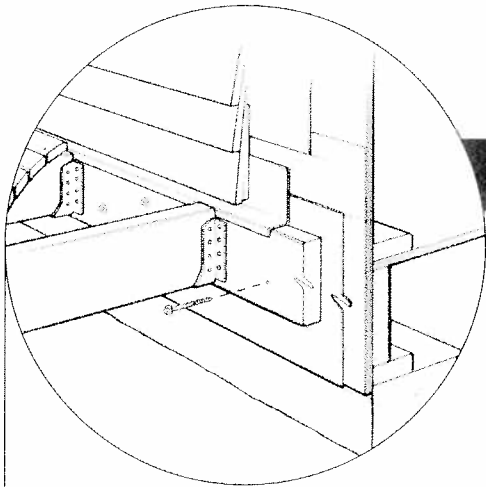

## DECK LEDGER TO RIM JOIST

### CONNECTION DETAILS

The LedgerLok Ledger Board Fastener has been designed specifically for attaching the deck ledger to the rim joist of the house in a code compliant manner.

#### 2009 IRC Code Reference: 502.2.2.2 – Alternate Deck Ledger Connections

As stated in this IRC section, deck ledger connections can be designed in accordance with accepted engineering practices. Using tested and approved values as published in ICC-ES Report #1078, the LedgerLok can be used to meet this code requirement. In addition, the proprietary coating on this fastener exceeds the corrosion resistance of code approved hot-dipped galvanized coatings.

### INSTALLATION PROCEDURES

- Choose 3 $\frac{3}{8}$ " or 5" LedgerLok so that threads fully engage the rim material and fastener tip extends beyond the inside face of the rim joist.
- Use a high torque,  $\frac{1}{2}$ " variable speed drill (18V if cordless).
- Follow the minimum spacing and fastening patterns from Figure 1 and Table 1.
- Install fasteners through the ledger and sheathing. Continue into the rim joist until the washer head is drawn firm and flush to the ledger board. Do not overdrive.

### CORROSION STATEMENT

LedgerLok has been tested and is approved for use in above ground (.25 pcf) and ground contact (.40 pcf) ACQ treated wood applications.

Under the recently adopted ICC standard (AC257 – Acceptance Criteria for Corrosion-Resistant Fasteners and Evaluation of Corrosion Effects of Wood Treatment Chemicals), the proprietary coating on this fastener has been tested and found to exceed the corrosion protection offered by code compliant hot-dipped galvanized (HDG) coatings. Under the "Alternative Materials" provision of the code (IRC & IBC, Section 104.11), inspecting agencies and specifying design professionals may use the results of this test report to show equivalency of the LedgerLok coating to the approved HDG coatings, thereby meeting code.

For applications within 1,000 feet of saltwater, we recommend the use of a stainless steel fastener.

### SPACING REQUIREMENTS

Fasteners should be staggered in a "W" pattern and spaced as follows:

- A. Minimum end distance = 3 $\frac{3}{4}$ "
- B. Minimum edge distance = 1 $\frac{3}{4}$ "
- C. On-center spacing = Per Table 1

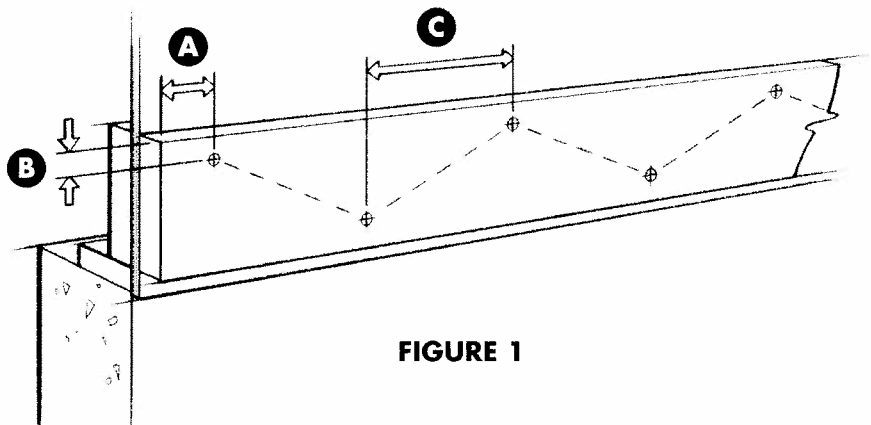

FIGURE 1



Effective until January 1, 2010. Updated information must be obtained after this date.

153 BOWLES ROAD, AGAWAM, MA 01001

413-789-0252

800-518-3569

WWW.FASTENMASTER.COM

**FASTENING PATTERN**

Based on the joist span of your deck (as measured from ledger to first supporting beam), and the live load required by your local code, determine the correct fastening pattern from Table 1 below.

**TABLE 1****Fastening pattern for attaching deck ledger to rim joist using LedgerLok**

Joist Span	6' and less	6'1" to 8'	8'1" to 10'	10'1" to 12'	12'1" to 14'
Live Load	<b>O.C. spacing of fasteners in inches</b>				
40 psf	12	9	7	6	5
60 psf	8	6	5	4	4

All fastening patterns outlined in the table above are based on the most conservative design values for the FastenMaster LedgerLok from ICC-ES Report ESR #1078 using the following materials:

- **Ledger:** 2 x 8 pressure-preservative-treated No. 2 grade Hem-Fir lumber or better. Douglas Fir-Larch, Southern Pine and all species above 0.43 specific gravity allowed.
- **Sheathing:**  $1\frac{1}{2}$ " or  $\frac{7}{16}$ " OSB sheathing. Additional materials between ledger and rim joist may be allowed. See guidelines below.
- **Rim joist:** 2 x \_ Spruce-Pine-Fir lumber or 1" minimum Engineered Wood (EW) Rim. EW Rim material must be solid LVL, LSL or PSL. For wood rims, all species above 0.42 specific gravity allowed.

A wet service factor has already been applied to all design values so as to provide the most conservative patterns for exposure to exterior conditions. **No further reductions need to be applied for wet service.**

The code-standard dead load for building materials of 10 pounds per square foot is assumed in all calculations above.

**EXAMPLE:**

1 Determine the live load requirement based on local code.

*Example: 40 psf*

2 Select the deck span as measured between ledger and first supporting beam.

*Example: 10' 6"*

3 Use these two values to find the proper spacing.

*Result: 6" O.C. spacing*

**GENERAL FASTENING GUIDELINES**

- The LedgerLok is not designed for use in masonry or concrete.
- Ledger connections shall be properly flashed to prevent water from contacting the rim joist.
- Deck ledger shall be minimum 2 x 8 pressure-preservative-treated No.2 grade lumber.
- As code requires, where positive connection to the rim joist cannot be inspected, deck shall be self supporting.
- Wood structural panel sheathing or gypsum board sheathing not exceeding 1" in thickness shall be permitted provided that the maximum distance between the inner face of the ledger board and the outer face of the rim joist is no greater than 1" and is properly fastened to the rim.
- Ledger cannot be attached over stucco, siding or brick veneer.
- LedgerLok is not designed for attaching to open web floor trusses, stud walls or house overhangs (cantilevers).
- Under the following conditions, a design professional should be consulted for proper spacing requirements:
  1. In areas where live load or snow load requirements exceed 60 lbs. per square foot.
  2. For decks designed to carry increased dead loads (ex: hot tubs, stationary planters).
  3. Three-season or fully enclosed decks supporting an overhead roof.
- All local code requirements and guidelines outlined on this technical bulletin must be followed for values outlined above to be applicable.

## RAFTER TAIL TO TOP PLATE

### CONNECTION DETAILS

The minimum fastening requirements for the rafter to top plate connection in the 2006/2009 International Residential Code (Table R602.3) require 2-16d nails toenailed. The 2006/2009 International Building Code (Table 2304.9.1) requires 3-8d nails toenailed. Both of these codes can be met by installing the FastenMaster TimberLok when the guidelines on this technical bulletin are followed. In many cases where increased wind uplift or seismic conditions require a stronger rafter to top plate connection, this fastening method may also be used to replace metal ties and straps.

### FASTENING METHOD

**CAN BE USED WHEN RAFTER IS ALIGNED OVER OR BETWEEN WALL STUDS**

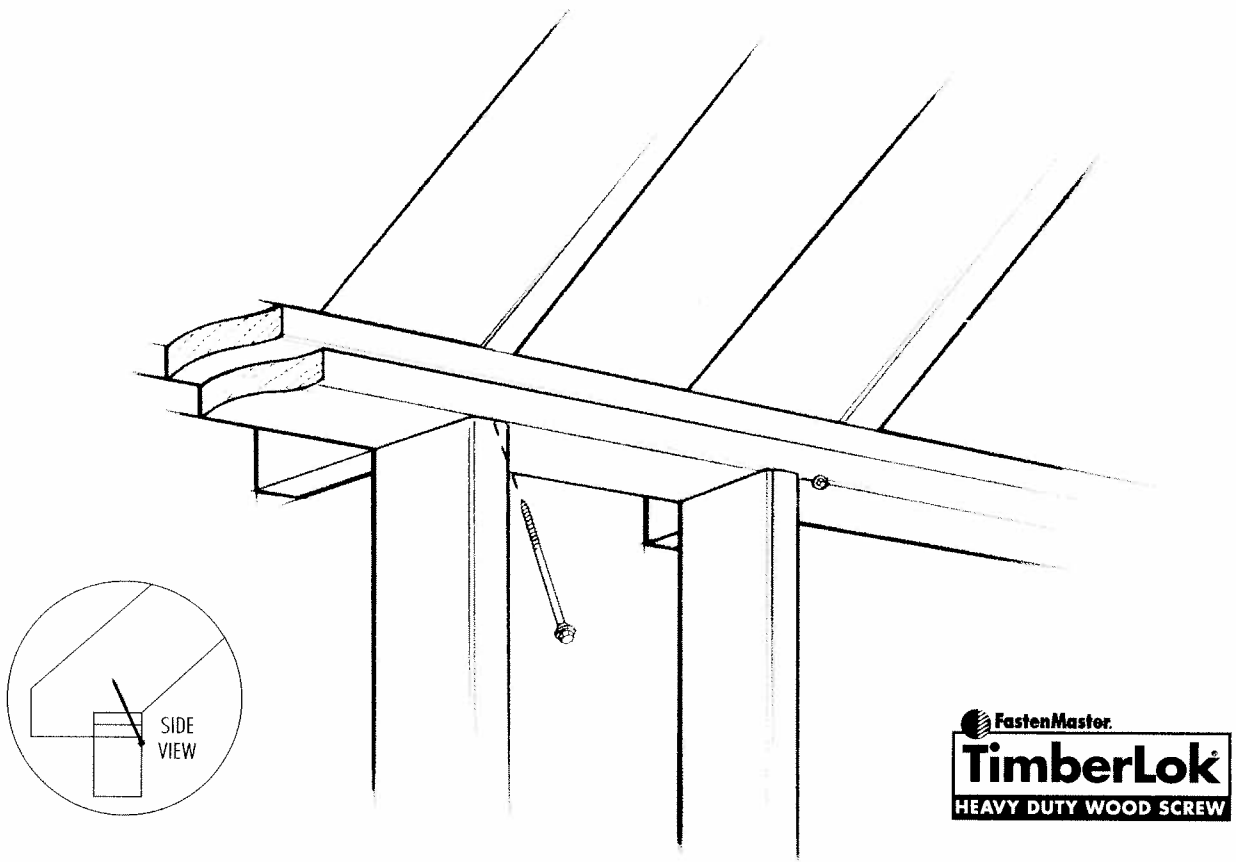

- Use a 6" FastenMaster TimberLok.
- Where the rafter is directly over the wall stud, insert fastener point between the bottom of the top plate and the top of the stud.
- Where the rafter is located between two studs, insert fastener point on bottom surface of the top plate no greater than 1/2" from the inside edge of the plate.
- Drive fastener through double top plate at a 22 1/2° angle (+/- 5°) and into the center of the rafter.
- Fastener must be driven into the center of the 1 1/2" rafter edge (+/- 1/4") with the threads fully embedded into the rafter.
- Bring the fastener head flush with the wood surface.



**Effective until January 1, 2010.** Updated information must be obtained after this date.

153 BOWLES ROAD, AGAWAM, MA 01001

413-789-0252

800-518-3569

WWW.FASTENMASTER.COM

**FASTENER DESIGN LOADS**

The FastenMaster TimberLok load values in Table 1 can be used by a design professional to determine suitability of these fasteners in a rafter to top plate connection.

- Where the uplift and/or lateral design loads have been provided on the building plans, the allowable loads in Table 1 can be compared to the plan values to make sure they are met or exceeded by use of this fastening method.
- If ties or straps have been called for to resist uplift and lateral forces, the allowable loads in Table 1 should be compared to the manufacturer's published values for the specified connector to ensure that this fastening method meets or exceeds these loads.
- In cases where the above two methods are not available and the wind speed from IRC Figure 301.2(4) equals or exceeds 100 mph in hurricane-prone regions, or 110 mph elsewhere, the design loads of this connection can be determined by a design professional from one of the following three sources and compared to Table 1:

1. American Forest and Paper Association (AF&PA) Wood Frame Construction Manual for One- and Two-Family Dwellings (WFCM).  
A sample of this chart is shown below.
2. International Code Council (ICC) Standard for the Residential Construction in High Wind Regions (ICC-600).
3. Minimum Design Loads for Buildings and Other Structures (ASCE-7).

**TABLE 1**

<b>TimberLok Design Loads for Rafter to Top Plate Connections</b>						
Wood Species	SPF/HF		Douglas Fir		Southern Pine	
Load Type	Uplift	Lateral/Shear	Uplift	Lateral/Shear	Uplift	Lateral/Shear
<b>Allowable Load</b>	420	320	540	380	620	410

- TimberLok values above are based on ICC-ES Report #1078 and independently verified through testing to ASTM D-1761.
- A standard wind load duration factor has been applied to these values per NDS Table 2.3.2. Other applicable NDS adjustment factors are at the discretion of a design professional.
- These values apply only to the top plate to rafter connection and assume that the fastener is properly installed per the instructions on this bulletin.

**Sample Wind Loads**

Table 2 below represents common design wind loads on rafter to top plate connections taken from the AF&PA Wood Frame Construction Manual, High Wind Zone Exposure B, Wall Connections at Load Bearing Walls.

**TABLE 2**

WIND ZONE (MPH)	RAFTER SPACING	Roof Framing Span (ft.)							LATERAL (LB.)	SHEAR (LB.)
		12	16	20	24	28	32	36		
		UPLIFT (lb.)								
90	16" o.c.	82	96	110	125	139	154	168	119	52
90	24" o.c.	123	144	165	187	209	230	252	178	78
100	16" o.c.	124	147	170	193	217	240	264	145	64
100	24" o.c.	186	220	255	290	325	360	396	218	96
110	16" o.c.	170	203	236	269	303	336	370	176	77
110	24" o.c.	255	304	354	404	454	504	554	264	116
120	16" o.c.	220	264	308	352	397	441	486	209	93
120	24" o.c.	331	396	462	528	595	661	728	314	140
130	16" o.c.	275	331	386	442	499	555	611	247	109
130	24" o.c.	413	496	580	664	748	833	917	370	164

This chart is used as an example only and should not be the sole source to design the connection.